

# Subject and non-subject *ex-situ* focus in Dagbani

Sam Issah and Peter W. Smith

September 2018

## Abstract

This paper offers a description and account of the patterns of *ex-situ* focus in Dagbani. We show that there are two syntactic strategies for creating *ex-situ* focus in the language, one involving A'-movement to the left periphery, and the second involving base generation in the left periphery combined with coreference to a resumptive pronoun. Furthermore, we argue that subjects are difficult to move from Spec,TP to Spec,CP in the left-periphery because of *anti-locality*, which creates a tension when trying to focus subject, which are required to derivationally fill the specifier of both positions. We further show that what looks to be a two-way distinction between the behaviour of subjects and non-subjects in the language is in fact a three-way distinction between matrix subjects, embedded subjects and non-subjects, which arises due to there being two methods for Dagbani to resolve the antilocality problem of subject movement, and so local subjects solve the problem differently to non-local subjects.

## 1 Introduction

Subjects are difficult to move. This much has been known for a long time, with various attempts to derive the effect, such as the Empty Category Principle (Chomsky, 1981), Relativised Minimality (Rizzi, 1990), and Criterial Freezing (Rizzi and Shlonsky, 2007). Recent years have seen a renewed interest in these effects, coupled with approaches that try to subsume the problem under *antilocality*, the notion that movement cannot be too short. Approaches like Erlewine (2016), Bošković (2016), and Douglas (2017) have gone in this vein, who each argue that movement from the canonical subject position Spec,TP to Spec,CP is too short. These authors argue for a particular formulation of antilocality, Erlewine (2016) terms *Spec-to-Spec Anti-Locality*:<sup>1</sup>

- (1) Spec-to-Spec Anti-locality  
A'-movement of a phrase from the Specifier of XP must cross a maximal projection other than XP.

---

<sup>1</sup>(1) is a descriptive statement, see Bošković (2016) and Douglas (2017) for attempts to derive it through the labeling mechanism of Chomsky (2013). It should also be noted that this version of anti-locality differs from others that are on the market. Rather than give an overview here, we refer the reader to Grohmann (2011) for an overview. We will assume throughout this paper that something akin to (1) holds at least for movement from Spec,TP.

A prohibition on movement such as this is particularly relevant for the case of subjects. Supposing, as is fairly standard, that subjects canonically lie in Spec,TP (for more discussion on multiple positions within TP, see among others Bobaljik and Jonas 1996 and McCloskey 1996), then if (1) holds, a subject will not be able to move from that position to the lowest projection of CP, since that movement will be too short:

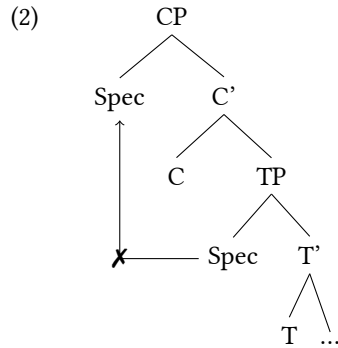

Support for some version of the prohibition on movement such as (1) comes from well known observations regarding subject movement, such as *anti agreement-effects* (Ouhalla, 1993; Richards, 1997), where agreement that would be expected does not arise. For instance, in the following Berber examples, *wh*-extraction of the subject does not allow for the otherwise expected subject agreement morphology on the verb.<sup>2</sup>

- (3) a. Man tamghart ay yzrin Mohand?  
 which woman C see.PART Mohand  
 ‘Which woman saw Mohand?’ [Ouhalla, 1993, p. 479]
- b. \*Man tamghart ay t-zra Mohand?  
 which woman C 3.F.SG-saw Mohand?

A clear line of analysis of this effect is that agreement is triggered once the subject moves to Spec,TP. Agreement is missing in the second example because the subject has not moved to Spec,TP at any point, but rather has moved directly to Spec,CP. In the case of A'-movement then, it seems that languages that display this effect avoid Spec,TP, ostensibly to avoid being stuck there and unable to move into the left periphery.

Whilst it is important to retain a healthy degree of academic scepticism around the formulation of anti-locality in (1) – there are various formulations of antilocality on the market, and (1) is certainly one of the more strident formulations<sup>3</sup> – it makes clear, testable predictions, and allows us to follow well defined analytical paths. To our eyes, then, it is more than worthy of further attention. It is our aim in this paper to investigate restrictions on subject A'-movement further, specifically through looking at *ex-situ* focus in Dagbani, a Gur language spoken in Northern Ghana. As

<sup>2</sup>Throughout this paper, unless otherwise indicated, all example sentences come from our own consultation with native speakers of the relevant languages.

<sup>3</sup>Not necessarily a bad thing, of course.

we will show, Dagbani presents an interesting, and to some degree unique, cluster of properties that bear on the question of subject movement and related matters. Along the way, we will take (1) as being a genuine constraint on movement, and explore what this means for the derivation of focus constructions in Dagbani. Additionally, we will touch upon other languages of the region, to draw relevant comparisons to issues that arise as we proceed.

Specifically, we propose that in Dagbani, focus movement of subjects is complicated by a requirement that Spec,TP cannot be skipped in the way outlined above for Berber; that is, the EPP is a strong requirement in Dagbani and cannot be ignored (*c.f.* Adesola 2010 for Yoruba). Since *ex-situ* focus is analysed as movement of the focalised element to the left periphery of the clause, this entails that focussed subjects will necessarily behave differently to other arguments when under focus. We will show that this leads to there being two strategies for *ex-situ* focus of subjects, both used in Dagbani. In the first strategy, used primarily by embedded subjects when moving to a non-local (i.e. immediately dominating) CP, a resumptive pronoun is generated in the lower clause, fills Spec,TP, and is then linked to the focussed element in the matrix left periphery. As we will show, this avoids antilocal movement of the subject because the item filling the embedded Spec,TP does not move beyond that point. Regarding matrix subjects (and more generally, local subject movement – see below), we propose that Dagbani has innovated a more complex left-periphery to enable the matrix subject to circumvent the restriction in (1), such that the focussed subject can cross some phrase other than TP. In such instances, we propose that the CP is replicated on top of the existing CP, creating a complex shell structure. Previewing the discussion below, we will propose that focussed elements that are not locally moved subjects move to Spec,CP in (4), whereas subjects that move locally must use the landing site in (5). We will discuss this more complicated structure, and justify it in further detail below. A crucial piece of analysis in favour of our account is that one can morphologically distinguish between the two structures in Dagbani, since locally moved subjects appear with one focus marker, and all other *ex-situ* foci appear with a different one.

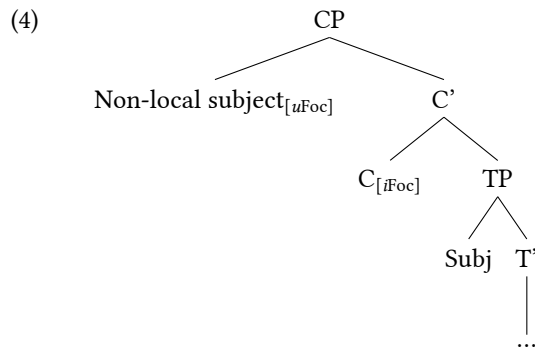

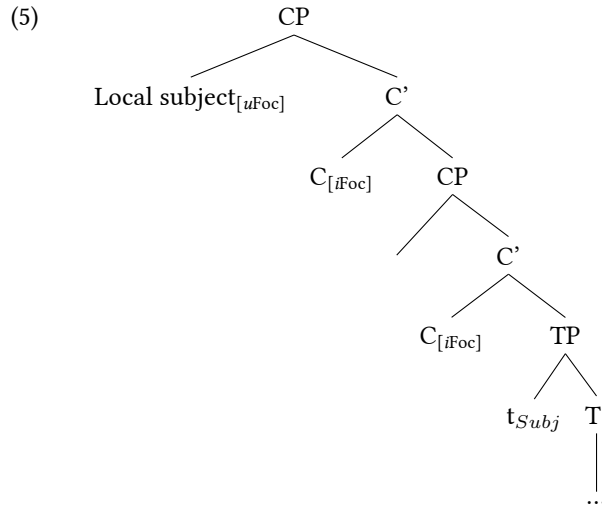

The paper is organised as follows. In section 2 we discuss background information to Dagbani, including its relevant syntactic characteristics. In section 3 we discuss how matrix subjects, embedded subjects and non-subjects all differ in relation to focus movement in Dagbani, showing that what has been thus far characterised as a two-way distinction between argument types (Fiedler et al., 2010; Samuel Alhassan Issah, 2012) is actually a three-way distinction that distinguishes local subject movement, non-local subject movement, and movement of other arguments. Section 4 discusses how embedded subjects differ from non-subjects, and shows that underneath this three way distinction lie two different strategies used in *ex-situ* focus in Dagbani, a movement strategy and a resumption strategy. In section 5 we return to the issue of locally focussed subjects, and show that they are forced into a different position altogether from the other elements in Dagbani. Section 6 compares the account with recent proposals for subject specific behaviour where it is proposed that C and T can be bundled on a single head (Bennet, Akinlabi, and Connell, 2012; Martinić, 2015; Erlewine, *in press*), and we show that such an analysis is not appropriate for Dagbani. We conclude the paper in section 7.

## 2 Dagbani: Background Information

Dagbani is a Mabia (Gur) language spoken in northern Ghana. It belongs to the Oti-Volta subfamily of the Niger-Congo language family. The language has three major dialects; the Eastern dialect (Nayahali) which is spoken in and around Yendi; the Western dialect (Tomosili), spoken within Tamale and its surroundings and the Nanuni dialect spoken in Nanuj (Samuel Alhassan Issah, 2008; Hudu, 2010). These dialects are mutually intelligible and differences among them are mainly based on tonal variation and a few lexical differences. There are approximately two million speakers of Dagbani predominantly found in the Northern part of Ghana. It is genetically related to languages such as Kusaal, Mampruli, Dagaare, Gurene and Safaliba.

Its basic argument alignment is rigidly SVO, with mostly analytic verbal morphology.

- (6) a. Abu tú            bíá máá  
 Abu insult.PERF child DEF  
 ‘Abu has insulted the child’  
 b. \*Bíá máá Abu tú  
 child DEF Abu insult.PERF  
 ‘Abu has insulted the child’  
 c. \*Abu bíá máá tú  
 Abu child DEF insult.PERF  
 ‘Abu has insulted the child’

In ditransitive constructions, where we have a direct and indirect object, these constituents are strictly ordered such that the closest to the verb is the indirect object followed by the direct object (7-a) and then the adjunct (adverbial element) if any (7-b). When this order is defied, the sentences that are formed are ungrammatical (7-c) and (7-d).

- (7) a. páyà máá tí            ò bíá búkù pálli  
 woman DEF give.PERF 3SG child book new  
 ‘The woman has given her child a new book’  
 b. páyà máá tí            ò má búkù pálli zúnò  
 woman DEF give.PERF 3SG mother book new today  
 ‘The woman has given her mother a new book today’  
 c. \*páyà máá tí            búkù pálli ò má zúnò  
 woman DEF give.PERF book new 3SG mother today  
 ‘The woman has given her mother a new book today’  
 d. \*búkù pálli páyà máá tí            ò má zúnò  
 book new woman DEF give.PERF 3SG mother today  
 ‘The woman has given her mother a new book today’

For more information about the general grammatical properties of the language, we refer the reader to Olawsky (1999), Samuel Alhassan Issah (2008), and Samuel Alhassan Issah (in prep).

### 3 Ex-situ Focus in Dagbani

#### 3.1 Subject versus non-subject focus

With regard to focus constructions, which form the major topic of interest in this paper, Dagbani allows both *ex-situ* and *in-situ* focus. With *ex-situ* focus, the element that is in focus is moved to the left periphery of the sentence where the entire constituent is followed by a focus marker, either *ka* or a nasal consonant *n, m* or *ŋ* (which is homorganic with the place of the following consonant). For convenience we will refer to this marker as *n*, but the reader should bear in mind that its realisation is determined by the phonology of the following consonant.

The choice between the markers is at first glance conditioned by the grammatical role of the argument, with subjects appearing with *n*, and all other focused items appearing with *ka*.<sup>4</sup>

- (8) a. Abu *n* dá búkù máá  
 Abu FOC buy.PERF book DEF  
 ‘ABU bought the book.’ (subject focus)
- b. \*Abu *ka* dá búkù máá  
 Abu FOC buy.PERF book DEF  
*intended*: ‘ABU bought the book.’ (subject focus)
- c. Búá máá *ka* Abu dá  
 goat DEF FOC Abu buy.PERF  
 ‘Abu bought THE GOAT.’ (object focus)
- d. \*Búá máá *n* Abu dá  
 goat DEF FOC Abu buy.PERF  
*intended*: ‘Abu bought THE GOAT.’

Though we will diverge from this viewpoint, for reasons that will become clear shortly (see section 3.2), the view up to now taken in the literature (for instance Samuel Alhasan Issah 2012) is that the distribution of the focus markers is determined by grammatical role. That is, *n* combines with subjects in focus, and *ka* combines with all other focussed elements. This is supported by the fact that a similar division of focus markers apparently dividing subjects and other arguments is seen in related Gur languages.<sup>5</sup> For instance, the following from Gurene (Dakubu, 2003) shows that there is an optional focus marker *n* which marks focussed subjects, and another marker *ti* used to mark non-subjects.

- (9) a. a-ni *n* zàa nyé bòdàa lá?  
 a-WH FOC yesterday see man DEF  
 ‘Who saw the man yesterday?’ [Dakubu 2003, p. 4]
- b. á-ni ñmè ʔi  
 a-WH beat 3SG.INT  
 ‘Who beat him?’ [Dakubu 2003, p. 4]
- c. bá-ni *ti* fò nyé?  
 ba-WH FOC 2SG see  
 ‘Who (what group) did you see?’ [Dakubu 2003, p. 4]
- d. lög-kó-nì *ti* fò nyé?  
 thing-ku-WH FOC 2SG see  
 ‘Which thing did you see?’ [Dakubu 2003, p. 4]

We illustrate with two further examples, both Gur (Mabia) languages. Firstly, Kusaal (Abubakari, 2016):

- (10) a. múi *ka* bà sá dī.  
 rice FOC 3PL PST eat

<sup>4</sup>For the Dagbani examples, we translate the sentences with the focussed element in capitals.

<sup>5</sup>See also Leffel (2011) for a similar situation in Masalit.

- 'It is rice that they ate yesterday (not beans)'. [Abubakari 2016]  
 b. Dáú lá í dā' bósóg lá.  
 man DEF FOC buy goat DEF  
 'It is the man that bought the goat (not the woman)' [Abubakari 2016]

Secondly, (the Pisaali dialect of) Sisaali (Dumah, 2016):

- (11) a. Duma yɔbɔ loori.  
 Duma buy car.  
 'Duma has bought a car' [Dumah 2016, p. 6]  
 b. Duma rɛ yɔbɔ loori.  
 Duma FOC buy car.  
 'It is Duma who bought a car' [Dumah 2016, p. 6]  
 c. Emma nyɔɔ daasi.  
 Emma burn sticks  
 'Emma burnt sticks.' [Dumah 2016, p. 7]  
 d. Daasi nɛ Emma nyɔɔ  
 sticks FOC Emma burnt  
 'It is sticks that Emma burnt.' [Dumah 2016, p. 7]

This is not an exhaustive list of languages with this property and we refer the reader to Kalinowski (2015) for a more comprehensive survey of focus marking in African languages, where Gur languages are included in the survey.

Returning to Dagbani, it is important to stress that *ka* and *n* are focus markers, since they only appear in contexts of new information focus (questions, answers, contrastive focus *etc*). A reviewer questions whether they could be markers that indicate any A'-dependency. We claim that they are not, which can be shown by the following sentences, all canonical instances of A'-movement, but not focus. As can be seen, *n* and *ka* do not show up in relative clauses, tough-movement constructions, or in comparative clauses.

- (12) a. bíá<sub>i</sub> sò (\*ń) ɲùn t<sub>i</sub> kpí máá  
 girl REL FOC who die DEF  
 'The child who has died.'  
 b. chéché<sub>i</sub> shélí (\*kà) á nì nyá-ø t<sub>i</sub> máá  
 bicycle REL FOC 2SG PRT see.PFV DEF  
 'the bicycle that you have seen.'
- (13) a. Neindoo yòhím-bú bì tó  
 Neindooo please-NMLZ NEG hard  
 'It is easy to please Neindoo.' Lit: Neindoo is not hard to please  
 b. Gbáj ɲó nyá-bú tó  
 book this see-NMLZ hard  
 'It is difficult to get this book.'  
 c. Mùgísígú ɲó málí-bú tó  
 Problem this solve-NMLZ hard  
 'This problem is hard to solve.'

- (14) a. Nírìbá kana gàrí tí nì dì tèhí shém  
 People come pass 2PL PRT PST think way  
 ‘More People have come than we had expected’  
 b. Chentiwuni v̀alím g̀arí má  
 Chentiwuni smart pass me  
 ‘Chentiwuni is smarter than me.’

Note that with the last two instances, tough-movement and comparative clauses, respectively, it is not immediately apparent that A'-movement is involved at all. Relative clauses, however, do seem to involve similar properties to English, and they do not allow for *n* and *ka*. We leave a fuller investigation of A'-movement in Dagbani for future work, but it suffices to note here that *n* and *ka* are focus markers, and not general indicators of an A'-dependency.

As we have seen, *n* and *ka* appear to mark whether a subject or a non-subject has been focussed. A further evidence of a split between subjects and non-subjects can be seen in the behaviour of the two classes with regards to *in-situ* focus. Focussed subjects are not allowed to appear *in-situ*, whilst all other elements are. It is easy to see that *in-situ* focus is possible with non-subjects. We see that (15-b) can serve as the answer to the question in (15-a), when the object is left in its base position.<sup>6</sup>

- (15) a. B̀ò k̀à ò dú?  
 What FOC 3SG climb.PERF  
 ‘What has s/he climbed?’  
 b. Ò dú lá k̀yú  
 3SG climb.PERF FOC stool  
 ‘S/he has climbed a stool.’<sup>7</sup>

Since *ka* appears only in the left-periphery, and never in *in-situ* positions, we must rely on the context determining that we are truly dealing with focus here. Answers to wh-questions are generally taken to be focussed since they contain new information. Thus, movement to the left periphery is not obligatory for Dagbani focus.<sup>8</sup> It is difficult to show that subjects do not allow for *in-situ* focus. With subjects, movement to the left-periphery is string vacuous; the canonical subject position is Spec,TP and already the leftmost element of the focus. However, one of the characteristics of *in-situ* focus in Dagbani is that the focus marker cannot appear with the *in-situ* focus. Thus, in (15-b), the sentence would be ungrammatical if *ka* were to accompany the object. We can utilise this property for subjects. If subjects were allowed to remain *in-situ* under focus, we would expect that they can appear without the focus marker, even when interpreted as in focus. The following pair of examples demonstrate that, leaving the subject in its base position without a focus marker yields a grammatical sentence,

<sup>6</sup>It is no coincidence that the question formation in (15-a) uses the same focus morpheme: question formation with q-words moved to the left-periphery and *ex-situ* focus are formed in the same way in Dagbani.

<sup>7</sup>*lá* is another focus marker in Dagbani, that appears only *in-situ* for objects, adjuncts and VPs. It is not obligatory for *in-situ* object foci. A fuller discussion of *LÁ* as a focus particle is given in Samuel Alhassan Issah (in prep), to which we refer the reader.

<sup>8</sup>The example in (15) can alternate with the *ex-situ* variant. Whilst there are possibly subtle differences between the two (*ex-situ* tends to express exhaustivity or surprise), they do not factor into our discussion here and we ignore the distinction between the two.



however the sentence is infelicitous in the context.

- (16) a. ɲùní ní cháj púú máá ní?  
 who FOC go.PERF farm DEF LOC  
 ‘Who has gone to the farm?’  
 b. #Tòhá máá cháj púú máá ní?  
 hunter DEF go-PERF farm DEF LOC  
 ‘The hunter has gone to the farm.’

The interpretation of the sentence is infelicitous in this example. Thus, the focus marker is obligatory for subjects when in focus, and we take this to mean that *in-situ* focus is not possible for subjects, in contrast to other elements in the sentence.

Dagbani is thus a language where focus can be optionally *ex-situ* or *in-situ* which is somewhat frequently attested in the languages of West Africa (see Hartmann and Zimmermann 2007a on Tangele, Hartmann and Zimmermann 2007b on Hausa, Hartmann and Zimmermann 2009 on Guruntum, and Hartmann and Zimmermann 2012 on Bura). As to why Dagbani allows both *in-situ* and *ex-situ* focus is doubtless an interesting question, but not one that is of concern to us here, and for a discussion we refer the reader to Samuel Alhassan Issah (in prep). For now, let us simply assume that whatever is responsible for driving movement to the left periphery is optionally present or operational in Dagbani, and thus, with certain exceptions, focussed elements are only sometimes compelled to move to Spec,CP.

In certain respects, some of this behaviour is not all that surprising. It has already been noted in the literature (Fiedler et al., 2010) that languages in the West African region (Dagbani being one of the languages in their study) show special behaviour regarding putting subjects into focus. Specifically, Fiedler et al. show that languages in this region mark focus on subjects differently and/or more robustly than on other elements, like objects or adjuncts. Dagbani is no exception here: subject focus is obligatorily marked, and it uses a different focus marker to other elements. Furthermore, it is not possible to focus subjects *in-situ*, which is possible for other elements.

*Ex-situ* focus always involves the focussed element appearing at the left edge of the clause, where it is followed by a focus marker, which as we have seen, varies according to the role of the focussed element. The element in the left periphery appears to be in that position by virtue of having moved there from its base position. This can be easily seen for objects, whose clause initial position contrasts with the regular position of objects, as well as the fact that when they are in this position, a focussed interpretation (with concomitant marking) is obligatory. Furthermore, we can see that this is a movement dependency because it is sensitive to island constraints. Consider the following example, where the focus is intended to lie only on one part of a coordination. It is not possible to move the conjunct to the left periphery and leave the rest of the coordination behind, which is a simple violation of the coordinate structure constraint (Ross, 1967).

- (17) a. \*Abu<sub>i</sub> kà Wumpini nyá [t<sub>i</sub> míní Chentiwuni].  
 Abu FOC Wumpini see.PERF [ and Chentiwuni]  
 ‘Wumpini saw ABU and Chentiwuni.’

- b. \*Chempang<sub>i</sub> kà Abu nyá Napari míni t<sub>i</sub>  
 Chempang FOC Abu see.PFV Napari and  
*intended:* ‘Abu saw Napari and CHEMPANG’

It is also not possible to move part of a coordination that lies in the subject position to the left periphery where it would combine with a focus marker.<sup>9</sup>

- (18) a. \*Abu<sub>i</sub> ñ [t<sub>i</sub> míni Chentiwuni] dá lòòrí  
 Abu FOC and Chentiwuni buy.PFV a.car  
 ‘ABU and Chentiwuni bought a car.’  
 b. \*Chentiwuni<sub>i</sub> ñ Abu míni t<sub>i</sub> dá lòòrí  
 Chentiwuni FOC Abu and buy.PFV a.car  
*intended:* ‘Abu and CHENIWUNI bought a car.’

Instead, if one wants to focus part of a coordination, then the focus marker must appear to the right of the entire coordination, even if only one of the conjuncts is in focus.

- (19) a. Napari míni Mbangba kà tí sà pùhí.  
 Napari and Mbangba FOC 1PL PST greet.PERF  
 ‘We greeted NAPARI and Mbangba yesterday.’  
 b. \*Napari kà míni Mbangba tí sà pùhí.  
 Napari FOC and Mbangba 1PL PST greet.PERF  
 Intended: ‘We greeted NAPARI and Mbangba yesterday.’  
 (20) a. \*Napari ñ míni Wumpini dá lòòrí  
 Napari FOC and Wumpini buy.PERF lorry  
 Intended: ‘NAPARI and Wumpini have bought a lorry’  
 b. Napari míni Wumpini ñ dá lòòrí  
 Napari and Wumpini FOC buy.PERF lorry  
 ‘NAPARI and Wumpini have bought a car.’

So, whilst the conjunction can move as an entire unit, a single conjunct is not free to move alone.

There are of course various ways in which movement could play a role in the creation of *ex-situ* focus. There are known to be quite some African languages which use a clefting strategy in focus constructions, such as Yoruba (Adesola, 2005). A key diagnostic of such languages is that the element that occurs when making a focus construction is used elsewhere as a verbal element. However, in Dagbani, there is no evidence to suggest that a clefting strategy is employed in the contexts under discussion. The existential verb in Dagbani is *nyɛ*, and not one of the markers that is used in focus contexts:

- (21) Bé nyéla kárimbíhí  
 3PL COP students  
 ‘They are students.’

<sup>9</sup>Foreshadowing the discussion later on a little, it should be noted that it is not possible to use a resumptive pronoun in either (17-a) or (18-a).

Furthermore, the focus markers can still appear in addition to the copula in a cleft construction (Hartmann and Sam Alhassan Issah, 2018):

- (22) Shikúrù ní nyé ò nì jé bínshèyú, (\*àmáá ò jé  
 school FOC COP 3SG DEP dislike.PERF.CJ school but 3SG dislike.PERF  
 tùmá gbá)  
 work TOO  
 ‘School is what he dislikes (\*but she dislikes work as well).’

Both focus markers, *ka* and *n* are used only in contexts involving focus, and do not serve any other verbal marking duty.<sup>10</sup> Thus, we assume that *ka* and *n* are focus heads in the left periphery, that both raise an element bearing focus to their specifier position.

### 3.2 Embedded Subjects

Though characterising the split as subject vs. other captures the data that we have looked at so far, and fits in nicely with the observation of Fiedler et al., things quickly become more complicated once we factor in the behaviour of embedded subjects. Somewhat surprisingly, embedded subjects combine with *ka* instead of the expected *n*.

- (23) Dó só kà ní wúm nì ò dá lòòrì  
 [man certain]<sub>i</sub> FOC 1SG hear.PERF.CJ that he buy.PERF.CJ car  
 ‘I heard that A (CERTAIN) MAN bought the car.’

A couple of points are worth elaborating on here. The use of *n* is strictly forbidden in this case, and *ka* is the only choice. It is possible to have focus where the embedded subject moves to the intermediate CP, in which case *n* is used, and *ka* is ungrammatical.

- (24) Wumpini yèlí-yá nì Mbangba ní/\*kà dá lòòrì  
 Wumpini say.PERF-DJ that Mbangba FOC buy.PERF car  
 ‘Wumpini said that MBANGBA bought a car.’

However, if the embedded subject is focussed to the matrix left-periphery, it is obligatory that *ka* be used. The observation that emerges then, is that *n* is used for focus of a subject to the closest left-periphery to the subject, and *ka* is used otherwise. *n* should then be seen not as a marker of matrix subjects in focus, but rather a marker that appears when an subject in focus undergoes local movement to the left periphery (i.e. the subject is focused without crossing a clause boundary).

A second interesting observation regarding (23) is the use of a resumptive pronoun in the subject position of the lower clause. The resumptive is obligatory here, and cannot be omitted. For all other types of arguments discussed above, the use of a

<sup>10</sup>There are forms with other meanings that are homophonous with these, such as the first person singular pronoun for *n* and a linker element with a meaning akin to ‘and so’ for *ka*. We assume that these instances of homophony are accidental, and do not consider them further in the remainder of the paper.

resumptive pronoun in the position before movement is ungrammatical. Thus, non-local subject focus is unique in Dagbani in that it requires a resumptive in the place of the ‘moved’ element.<sup>11</sup>

- (25) Búá só<sub>i</sub> kà nì tèhí nì \*(ò<sub>i</sub>) kpé dúú máá ní  
 Goat certain FOC 1SG think.PERF C 3SG enter room DEF LOC  
 ‘A CERTAIN GOAT that I think it has entered the room’

A final observation regarding embedded subjects and their behaviour under focus is the fact that syntactic islands can be violated without any loss in grammaticality, such as in the embedded coordination in (26-a).

- (26) a. Chempang<sub>i</sub> kà m wún nì \*(ò<sub>i</sub>) míní Abu dá lòòrí  
 Chempang<sub>i</sub> FOC I heard that he<sub>i</sub> and Abu buy.PERF car  
 ‘I heard that CHEMPANG and Abu bought a car.’  
 b. Chempang<sub>i</sub> kà Abu yèlí nì Napari míní o<sub>i</sub> dá lòòrí.  
 Chempang FOC Abu say.PERF that Napari and 3SG buy.PFV car  
 ‘Abu said that Napari and CHEMPANG bought a car.’

The ability to escape islands of non-locally focussed subjects does not just hold for coordinate structures, but rather other island effects as well, as can be seen with focus out of relative clauses, *wh*-islands and complex noun phrases in the examples below.

- (27) a. bí-púyím-bilá<sub>i</sub> so à nì tèhí ni ò<sub>i</sub> kànná máá  
 girl REL 2SG PRT think-PERF PRT 3SG come DEF  
 ‘The girl whom you think she has come.’  
 b. \*Bò kà á nyá-ø bíá [so ηun kú-ø máá?]  
 what FOC 2SG see-PERF child REL who kill-PERF DEF  
 ‘What have you seen the child who has killed?’
- (28) a. ηùn<sub>i</sub> kà á béhím bòndá lí kà ò<sub>i</sub> kàná?  
 who FOC 2SG wonder when FOC 3SG come.PERF  
 ‘Who do you wonder when she/he came?’  
 b. \*A béhím mí nì bòndá lí kà ò kòhí-ø bò?  
 1SG wonder FOC that when FOC 3SG sell-PERF what  
 ‘What do you wonder when he/she sold?’
- (29) a. ηùn<sub>i</sub> kà Wumpini tò jíná nì ò<sub>i</sub> nyá búá?  
 who FOC Wumpini make.PFV claim that 3SG see.PERF goat  
 Who has Wumpini made claim that he has seen a goat?  
 b. \*ηún<sub>i</sub> kà ò tó jíná ní ò<sub>i</sub> nyá-ø yá t<sub>i</sub>?  
 who FOC 3SG make claim that 3SG see-PERF  
 ‘Who has s/he made the claim that he has seen?’

This observation by itself does not appear too surprising. It is fairly well documented in the literature that the use of resumptive pronouns sometimes brings with it an ability to escape syntactic islands (McCloskey, 1990; Shlonsky, 1992; Saah, 1994; Aoun,

<sup>11</sup>As we will see below, we do not treat this as a movement operation.

Choueiri, and Hornstein, 2001; Salzmann, 2011; Salzmann, 2018). For Dagbani however, the use of resumptives does not appear to be forced by an island violation, but rather represents the usual strategy of non-local subject focus. Strikingly, in Dagbani, resumptives are not used as a general backup strategy for where movement fails. If we try to construct similar examples with extraction from an island within matrix subject or object positions, the use of a resumptive does not help, and the sentences remain ungrammatical, cf. (17-a).<sup>12</sup>

Thus, Dagbani seems to differ in that resumption is limited to a single position, irrespective of whether one is extracting from an island or not. For the sake of comparison, Salzmann (2011), Salzmann (2013), and Salzmann (2018) shows that resumption in Swiss German is in general limited to (and necessary for) indirect object A'-dependencies, but it is also permitted for subjects and objects embedded within islands, showing that whilst it is the obligatory strategy for indirect object A'-dependencies, it can also be used for other positions in case they are contained within an island. This does not appear to be the case in Dagbani.

### 3.3 Interim Summary

Whilst we started this section discussing how Dagbani appears to show a dichotomy in the behaviour of focused subjects versus all other focused elements, we have seen that it is in actual fact a three way distinction. On the one hand, local subject focus differs from non-local subject focus and non-subject focus in that locally moved subjects require the focus marker to be *n*, and not *ka*. In this respect, non-local subjects and non-subjects behave alike. However, local subjects and non-subjects form a natural class in that neither require (nor allow for) the use of resumptive pronouns, behaviour that sets both sets of items apart from non-local subjects. The key findings are summarised in Table 1.

## 4 Two Derivations for *ex-situ* Focus

We now turn to discussion of why there would be these two separate groupings of how elements behave under focus. We ignore for the time being local subject focus,

<sup>12</sup> In embedded clauses, it is marginally acceptable, if a little degraded, to use a resumptive in place of an element that has moved from within a coordination:

- (i) Nepari<sub>i</sub> kà Chempang wúm nì Wumpini nyá ò<sub>i</sub> míní Abu  
 Nepari FOC Chempang hear that Wumpini see 3SG and Abu  
 'Chempang heard that Wumpini saw NEPARI and Abu.'

Yet this is not reflective of a difference between matrix and embedded objects (see van Urk 2017 on Dinka), since a resumptive pronoun cannot in general take the place of an embedded object.

- (ii) \*Nepari<sub>i</sub> kà Chempang wúm nì Wumpini nyá ò<sub>i</sub>  
 Nepari FOC Chempang hear that Wumpini saw him  
 Intended: 'Chempang heard that Wumpini saw NEPARI.'

It appears as though the resumptive in (i) is an intrusive resumptive rather than a genuine resumptive pronoun.

	Marker	Resumption?	Island Extraction?
Local subject focus	n/m/ŋ	✗	✗
Non-local subject focus	ka	✓	✓
Non-subject focus	ka	✗	✗

Table 1: Interim Summary

returning to it in section 5, and concentrate attention on the difference between non-local subject focus and non-subject focus.

From the facts above, we can identify that there are two different strategies for encoding *ex-situ* focus in Dagbani. The first of these two strategies uses syntactic movement, where the element that is in focus moves to the left periphery of the clause into the specifier of a CP. This derivation is what we propose is used for non-subject focus. In the second derivation, used for non-local subject focus, we propose that the element in the left-periphery is base generated there, whilst a resumptive pronoun fills its canonical clausal position in the embedded clause. We will here outline the syntax of each of these derivations, before discussing why there are two focus markers in section 5.

#### 4.1 Movement to the Left Periphery

In the derivation where an element moves syntactically to the left periphery, we assume that the morpheme *ka* is the realisation of C which bears an interpretable focus feature,  $C_{[iFoc]}$ . The phrase which is interpreted as focussed bears an uninterpretable focus feature that must be associated with  $C_{[iFoc]}$ . We follow Bošković (2007) and Abels (2012) and assume that the features that force movement are present on the moved element. That is, we assume that the presence of an unvalued information structural feature on the item that will be in focus, and its need for a value forces it to seek to move to the specifier of a projection associated with a corresponding feature that is valued.<sup>13</sup> The movement is driven by the need to probe downwards in order to obtain a value. Subjects are also compelled to move to Spec,TP in order to satisfy the EPP, and assume the same explanation underlying this (potentially due to the presence of a  $[uT]$  feature on the subject Pesetsky and Torrego 2007). In the following sentence, where the object *búá* ‘goat’ is in focus, it has an unvalued  $[uFoc]$  feature, and so moves to Spec,CP in order to get a value and license it, whereas the subject is compelled to move to Spec,TP in order to license its  $[uT]$  feature. Not shown is movement of the object through Spec,vP, though it is assumed that this movement would take place.<sup>14</sup>

<sup>13</sup>Necessary for us is that the feature on the moving element can only be valued in a position that commands the matching valued feature. There are various mechanisms in the literature that will grant this, such as it being a matter of feature strength (Chomsky, 1995), a condition on AGREE (Epstein and Seely, 1999; Bošković, 2007), or it being a condition on the probe (Abels, 2012), amongst others. The choice does not impact the discussion here.

<sup>14</sup>Note that we use CP to indicate a head in the left periphery that is endowed with a  $[iFocus]$  feature. It is not intended to be a direct correlate of the FocP proposed in work in the cartographic tradition. In our sense then, FocP can then be read as a CP that is headed by a C that carries  $[iFocus]: C_{[iFoc]}$ . For this paper, it is important that we do not assume a universally expanded CP-layer along the lines that is proposed in such works (Rizzi, 1997). Specifically, we assume to be present only the projections that we see in the tree.

- (30) Búá máá kà ñ dá  
 goat DEF FOC 1SG buy.PERF  
 'I bought THE GOAT'

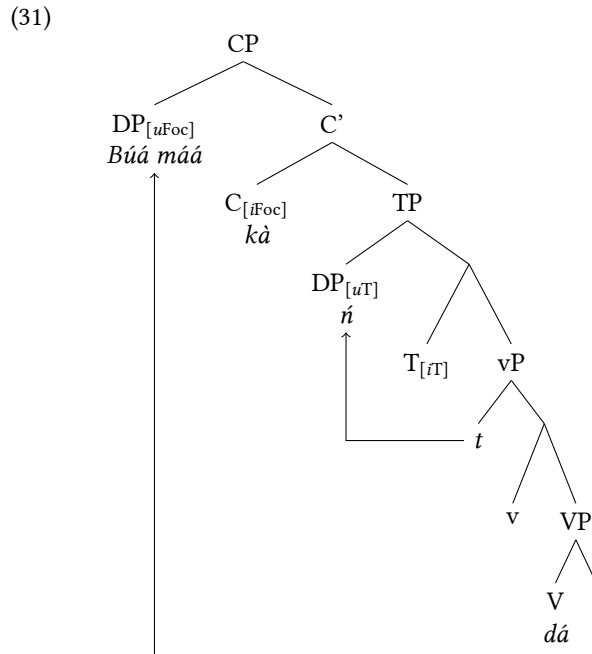

Certain properties follow from this derivation. Firstly, since we are dealing with a movement derivation, we do not expect that syntactic islands will be able to be escaped from here. Furthermore, since we are dealing with a derivation whereby the element is moved into the left periphery, we expect that the base position is filled by a trace (or deleted copy) of the moved element. This has the effect that there is a gap in the base position of the object. Again, ignoring local subject movement for the time being, we propose that this is the strategy that is employed in non-subject movement, accounting for the fact that we do not observe these elements either escaping islands or being associated with a resumptive pronoun.

## 4.2 Base Generation and Resumption

The second strategy that Dagbani resorts to with *ex-situ* focus, we propose, is a strategy of prolepsis, whereby the focussed element is base generated where it appears in the left-periphery, and is associated with another element elsewhere in the structure. This is what is found with non-local subject movement. Recall that these sentences superficially look very similar to those that are derived through the strategy outlined

---

It is an important question of how cartographic work squares with what we propose here, and not one that ought to be dismissed lightly. However, we do not have the space here for a full investigation of the left-periphery in Dagbani, and so hold such issues in abeyance and focus our attention on the question of whether (1) offers us anything useful in accounting for the cluster of properties identified in section 3 with the different types of focus movement in Dagbani.

in the previous subsection, in that there is a focussed element in the left periphery, to the left of *ka*. Since *ka*, by assumption, is the realisation of  $C_{[iFoc]}$ , then we must assume that in this derivation as well, the focussed element lies in Spec,CP. However, the superficial difference between non-locally moved subjects and non-subjects is that there is a resumptive pronoun in the subject position of the lower clause, whilst there is no corresponding resumptive with non-subject focus.

What we propose then, for this derivation, the element that occupies the specifier of Spec,CP is base generated directly there, and it becomes associated with a resumptive pronoun that acts as the subject of the lower clause. We assume that this is a relation of binding (following McCloskey 1990), and not one of movement where the resumptive is the spell-out of a lower copy. Furthermore, we assume that the pronoun in the embedded clause obeys the movements that we would standardly expect: it is base generated in the embedded Spec,vP and moves to Spec,TP to fulfill the EPP requirement of the embedded T. Thus, we are left with the following derivation, where we indicate movement relations with a solid arrow, and binding relations with a dashed arrow. The pronoun, which is generated as the specifier of vP, raises to Spec,TP to fill the EPP requirement on T. In the matrix clause, the focussed item is generated directly in Spec,CP, where it is associated with the resumptive pronoun in the lower clause so that the interpretations match. For the example in (23) (repeated below), we can give the derivation in (33).

- (32) Dó só      kà ní wúm      nì ò dá      lòòrí  
 [man certain]<sub>i</sub> FOC 1SG hear.PERF that 3SG buy.PERF car  
 ‘I heard that A (CERTAIN) MAN bought the car.’



(33)

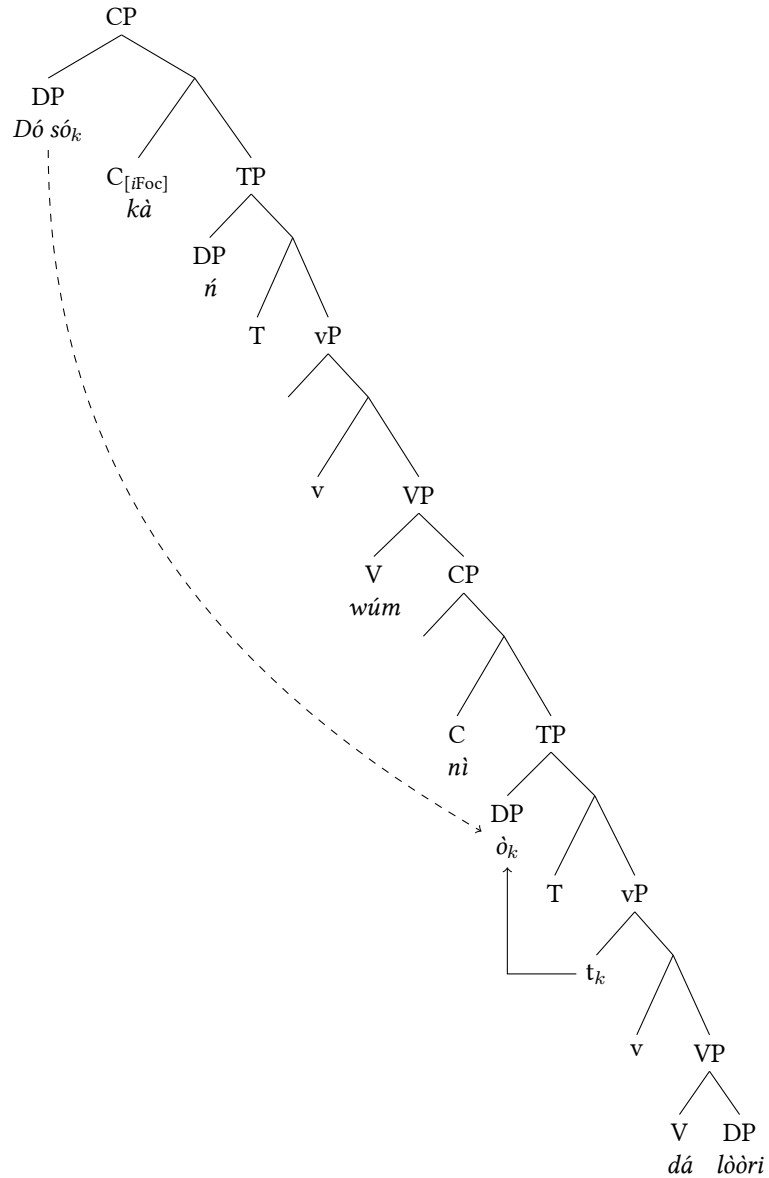

In this case, there is no movement relation connecting the element in the left periphery and the pronoun, and we thus expect that the connection between the two can ‘violate’ syntactic islands, as we have observed is the case for non-local subject focus. This is of course an illusion of sorts: there is no island violation because there is no element moving out of an island. Note that the resumptive is obligatory in this derivation. We know from the examples above that ungrammaticality results if the resumptive is omitted from contexts of non-local subject focus. This is expected in this

derivation: the resumptive is obligatory because it is required so that it can satisfy the EPP on the lower T, and receive the thematic information assigned to the lower subject. The element that lies in Spec,CP receives its interpretative properties, such as thematic role *etc.* through its association with the resumptive.

### 4.3 Why Use Resumption?

#### 4.3.1 The General Immobility of Subjects

A question that arises now, is why should this second strategy exist? Using resumption in place of moving a subject is perhaps not all that surprising, and could arguably be the result of a Criterion Freezing effect in the sense of Rizzi and Shlonsky (2007). Rizzi and Shlonsky argue that elements that occupy a criterial position are frozen in place. Since there is a subject position (SubjP), which is criterial, subjects that raise to Spec,SubjP cannot move beyond that. Crucially for them, once an element comes to occupy this position, it is frozen in place, and cannot move any further, say to fill a focus requirement in the left-periphery. In the event of there being some projection higher up that requires its specifier to be filled, then one strategy that languages can use to circumvent this conflict is through the use of a resumptive, allowing the higher specifier to be filled by a resumptive pronoun, which must remain in position.

There is a potential worry here, however, since it is not at all clear why this Criterion Freezing ought to hold. Whilst it does have the advantage that it equates the immobility of subjects with other immobile elements like foci and topics, in some sense it merely shifts the problem since it is not clear why objects are not treated in the same manner, i.e. why is there no ObjP, whose specifier position similarly renders an object immobile?

If we restrict attention to subjects, and ignore the immobility of topics and foci which we unfortunately cannot explore further here, a more promising alternative to us seems to be a spate of recent research which has attempted to account for the immobility of subjects through *anti-locality*. These works have looked at phenomena such as Agent Focus in Kaqchikel (Erlewine, 2016), *that*-trace effects in English (Douglas, 2017) and the subject condition more generally (Bošković, 2016). Such approaches have all proposed some variation on the theme of *antilocality*, where movement is too short to be licit. The papers each take as their starting point the following descriptive generalisation proposed by Erlewine (2016):

- (34) Spec-to-Spec Anti-locality  
A<sup>i</sup>-movement of a phrase from the Specifier of XP must cross a maximal projection other than XP.

Each of the accounts differ from the others in how they propose to derive (34). Our aim here is not to adjudicate between them but rather provide extra support for its status as a descriptive generalisation or some equivalent that prevents movement from Spec,TP to Spec,CP.<sup>15</sup> Both Douglas (2017) and Bošković (2016) suggest that it may

<sup>15</sup>We note that such a condition is at times too restrictive, and potentially forces us into corners we may not necessarily wish to venture into. Douglas (2017) notes that it effectively forces us to give up on the general view of subject movement to Spec,CP in V2 languages, and Bošković (2016) notes that we are forced

be derived through the theory of labeling, a conclusion which we see as reasonable. For concreteness, we adopt the explanation of Douglas (2017), who proposes that the reason why an element in Spec,TP cannot move to Spec,CP, is because the label of TP is more accurately  $\phi P$ ,  $\phi$  being the element that is shared between the subject and T (Chomsky, 2013). Because the subject is (partly) complicit in giving the label to the projection that dominates it has the effect that once CP is merged on top of  $\phi P$  (TP), movement of the subject to Spec,CP is effectively moving from the complement of C to the specifier of C. Effectively, as Douglas (2017, p. 14) puts it, “ $C^0$  has merged with the *same*  $\phi$  twice: once as its complement and again as its specifier.” Spec-to-Spec Antilocality is then a case of an illicit comp-to-spec movement, which Douglas proposes is ruled out through economy (Abels, 2003; Abels, 2012). We do not wish to dwell on the details here, so for the full technical implementation, we refer the reader to the cited works. However, we should note that this explanation means that Spec-to-spec antilocality in the way that we have been discussing it here, is not then a general condition governing A'-movement, but rather applicable to the movement of subjects to the left-periphery.

With this in mind, we can understand why the resumptive pronoun is necessary in non-local subject focus, rather than using the movement derivation that non-subject focus uses. The answer is that the intermediate stage of movement that would need to happen in a movement derivation is too short. The derivation would precede as follows, and shown graphically in (35). Firstly, the embedded subject moves from Spec,vP to Spec,TP to satisfy the EPP. Secondly, in order to move to the matrix clause, it would need to move to Spec,CP in order to escape the phase. Thirdly, it would move to the matrix Spec,vP to escape the lower phase in the matrix clause (assuming multiple specifiers are possible), before finally moving to the matrix Spec,CP. It is the second stage of this derivation that causes the problem, since the movement is too short. Effectively, when an element bears both [ $uT$ ] and [ $uFoc$ ], one of these features is not going to be licensed since a single element cannot move into the right positions to license both of them.

---

to assume the split-Infl hypothesis of Pollock (1989), if the same condition were to hold for A-movement, even for languages where there is little evidence that Infl is complex, which may in itself be problematic (Bobaljik and Thráinsson, 1998).

(35)

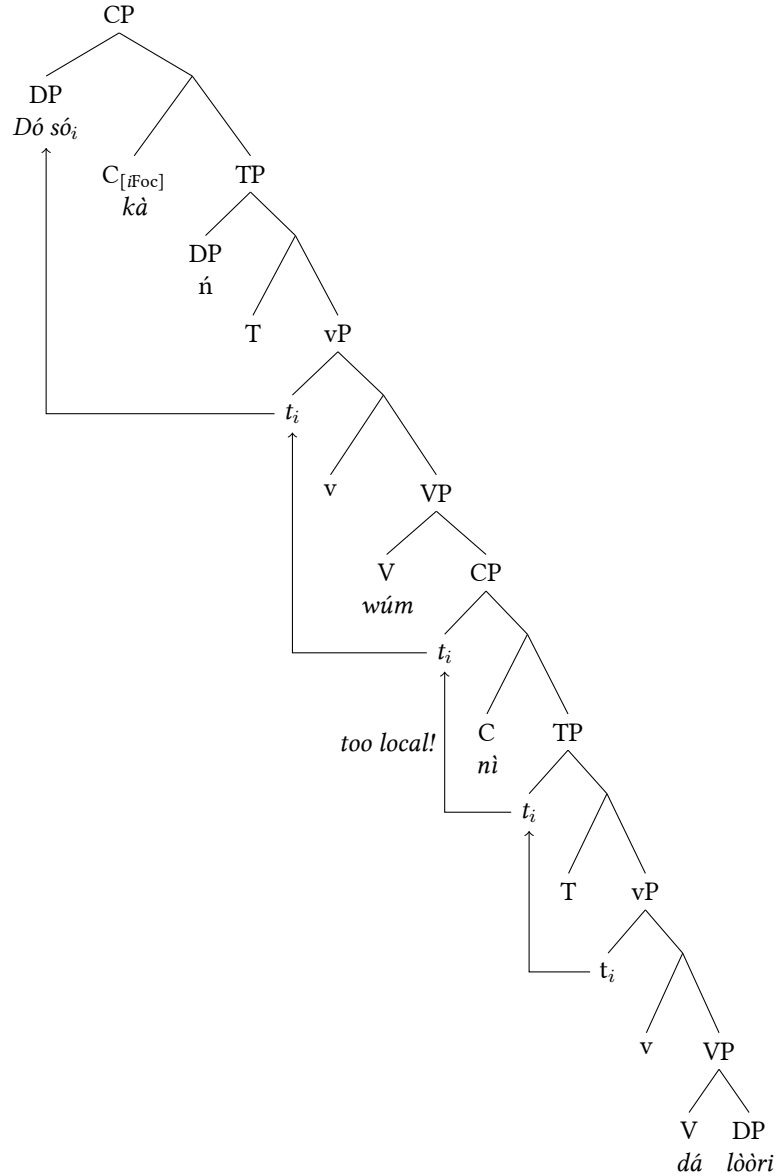

Using a proleptic derivation however, of base generation in the left-periphery and a resumptive pronoun lower down in the structure allows for the best of both worlds: the specifiers of both CP and the embedded Spec,TP are able to be filled by different elements, with nothing compelled to move between the two. Prolepsis, and splitting the features across two elements that are interpreted as the same (through A'-binding) thus allows for a converging derivation where the subject is interpreted as in focus.

The resumptive pronoun strategy then arises as a way of being able to ensure that

both the EPP on T, and the Focus feature in the left-periphery can be licensed. Due to antilocality, both cannot be carried out by a subject with a movement derivation, since the subject cannot make the movement from Spec,TP to Spec,CP.

#### 4.4 Can the resumptive be the spell-out of a trace?

Before ending this section, we are now in a position where we can consider whether our prolepsis analysis of resumption in Dagbani is correct, by considering it in light of an alternative analysis of how resumption is formed. It has become clear that some resumptive pronouns can at times be the spell-out of a movement step, see amongst others Engdahl (1985), Boeckx (2003), Kandybowicz (2007), Sichel (2014), and van Urk (2018). That is, whereas movements usually leave behind a gap, occasionally a pronoun can be inserted in place of said gap, if the position of the gap requires overt pronunciation (Landau, 2006; van Urk, 2018). It may be possible to recast the EPP requirement of Dagbani as a phonological requirement, such that all else being equal, it needs to be pronounced (see Salzmänn et al., 2013 on the idea of the EPP being phonological in nature.)

Dagbani, as we have seen, shows resumptive pronouns when a subject has moved non-locally, effectively singling out the embedded subject position. As a reviewer points out, this is similar in some extent to Swedish (Engdahl, 1985), where resumptives are used for just the subject position:

- (36) Vilket ord<sub>i</sub> visste ingen hur det<sub>i</sub> stavas?  
 which word knew no one how it is-spelled  
 ‘Which word did no one know how it is spelled?’ [Engdahl, 1985, p. 8]

The use of resumptives for subjects only is a fairly common pattern across the languages of West Africa, and for further discussion to the issues discussed here, we refer the reader to Authors (in prep). It is then worthwhile questioning whether the same explanation that holds for Swedish can underpin Dagbani.

Engdahl proposes that resumptive pronouns in Swedish are phonetically realised *wh*-variables: that is, they are effectively the spell-out of a trace of movement. In contrast to a language like English, where a subject extraction from the position immediately after a complementiser is ungrammatical, movement from such a position is allowed in Swedish. Engdahl’s explanation is that the subject position is properly governed by C in Swedish. Furthermore, the language idiosyncratically requires that a trace in Spec,TP be realised phonetically (cf. Engdahl’s discussion of Norwegian, which is argued to have the same government of the embedded subject position, but phonetically empty variables there). For the current discussion, let’s assume that the pronunciation of a pronoun in Swedish is forced by a phonological EPP effect.<sup>16</sup>

Suppose that this were the case for Dagbani. The embedded subject moves to Spec,TP, before it moves to Spec,CP. Then, when the structure is going to be pronounced, the embedded Spec,TP requires pronunciation, and as a result, the copy of

<sup>16</sup> Something would of course need to be said about why there are no resumptive pronouns in the matrix subject position. However, in the same way as above, one can imagine that the Highest Subject Restriction (McCloskey, 1990, discussed below) supercedes the pronunciation requirement.

the lower element is realised as a pronoun (see Landau 2006 for discussion).

As a reviewer points out, such an approach would circumvent the need for an antilocality explanation.<sup>17</sup> Under our proposal the resumptive is inserted because it bears the thematic information of the embedded predicate. The lexical DP that is in the left-periphery of course cannot do this, because if it did, then it would be unable to reach the left-periphery of the matrix clause, as antilocality would prevent it transiting through the embedded CP. However, all of this relies on antilocality ruling out movement from Spec,TP to Spec,CP. The alternative account would also provide an arguably more parsimonious theory, given that one does not need to assume both movement and prolepsis in the derivation of focus. Occam’s Razor favours the simpler explanation, providing all else is equal.

Much as we appreciate the desire to find a common analysis for Dagbani and languages like Swedish, we believe that our account is preferable since all else is not equal. Dagbani is not directly equivalent to Swedish, given that use of the resumptive pronoun correlates with an ability to escape islands, but this is not the case in Swedish (Engdahl, 1985). We do not see an easy way to handle this fact on the account where the resumptive is the spell-out of a trace, which is a notable drawback of movement-based theories of resumption (Salzmann, 2017; Salzmann, 2018)

## 5 Matrix subjects: Why two focus heads?

We are now in a position where we can consider locally moved subjects. We repeat the distribution of properties in Table 2, to see how the properties of locally moved subjects compare to non-subjects and non-locally moved subjects. Looking at the table, the obvious answer as to which strategy is used by locally moved subjects is that they use a movement strategy. Recall from the discussion of this strategy in section 4.1, the hallmark of this strategy is that there is no resumptive pronoun in the base position, rather a gap, and that syntactic islands cannot be violated. At first glance, this appears to be the case here, given that there is no resumptive pronoun, and that islands cannot be escaped from. However, the reader should recall that we argued in section 4.3.1 that the best possible option for subjects is that they use a resumption strategy, since this allows both Spec,TP and Spec,CP to be filled. Furthermore, movement from Spec,TP to Spec,CP was claimed there to be too local. Clearly, then, there are non-trivial questions to be answered before adopting wholesale the idea that local subject focus uses movement, instead of resumption. Coupled with this, there is a further issue that remains to be resolved: the realisation of the focus marker. Dagbani is somewhat unusual from a cross-linguistic perspective (though as discussed in section 3.1, similar to related Mabia (Gur) languages) in that it has different marking of focus for locally moved subjects versus other elements. Clearly then, whatever account is to be presented that relates to local subjects, should account for this fact as well.

---

<sup>17</sup>As we will discuss below, the explanation based on antilocality leads fairly naturally to an explanation of why there are two focus heads in Dagbani. It should be noted though, and borne in mind later on in the paper that one can accept our account for the presence of two focus heads laid out in section 5, whilst still maintaining an account where resumption is the spell-out of a trace.

	Marker	Resumption?	Island Extraction?	Strategy
Local subjects	n/m/lj	✗	✗	?
Non-local subjects	ka	✓	✓	Resumption
non-subjects	ka	✗	✗	Movement

Table 2: Interim Summary

### 5.1 A Movement Analysis of local subject focus

Before outlining our proposal, it is worthwhile considering why local subjects could not make use of resumption. There is a well documented restriction on resumptive pronouns, such that in many cases resumptive pronouns are not able to be used to refer to the highest subject, a condition identified for Irish by McCloskey (1979) and termed the *Highest Subject Restriction* (HSR). This is not a restriction on resumptives being used for subjects, but only they cannot be used in the closest subject position to the resumptive, as can be seen in the comparison of (37-a) and (37-b) below. Resumption and movement are generally in free variation in Irish, however, there are a couple of exceptions to this. The first is where the A'-dependency would cross an island boundary: in this case, only resumption can be used. The second, is when the A'-dependency targets the highest subject. In this case, only gapping can be used.

- (37) a. \*an fear a raibh sé breoite  
 them man c be.PST he ill  
 'the man that (he) was ill.' [McCloskey 1990, p. 210]
- b. an t-ór seo at chried corr-dhuine go raibh sé ann  
 this gold c believed a few people c was it there  
 'this gold that a few people believed (it) was there.' [McCloskey 1990, p. 210]

McCloskey (1990) proposes that the reason why resumptives are illicit in this position is because the antecedent and resumptive enter into a A'-binding relation, but one that cannot be too close. That is, it is an A'-equivalent of a Principle B effect, and that resumptives must be sufficiently far away from their binder.<sup>18</sup>

- (38) A pronoun must be A'-free in the least complete functional complex containing the pronoun and a subject distinct from the pronoun.

With this in mind, the lack of resumption in Dagbani for local subjects is brought into relief: the resumption strategy cannot be used because even though it is the best in terms of allowing both Spec,TP and Spec,CP to be filled for non-local subjects, for local subjects these two positions are too close and they violate (38). That is, there is no subject which separates the resumptive pronoun and its binder, and the pronoun is not A'-free. The same tension in *ex-situ* focus arises for matrix subjects as was identified for embedded subjects above: that they are asked to fulfill EPP requirements in both CP and TP. However, given that they cannot employ a resumptive pronoun to fill

<sup>18</sup>There are disagreements over exactly what underlies the HSR, see Salzmann (2018) for some concerns over McCloskey's proposal.

Spec,TP without violating (38), the conflict seems unresolvable.

However, given that movement to Spec,CP is also not an option due to antilocality, then we propose that Dagbani has been forced to innovate and has developed additional structure (for now, FP), with a higher projection above the one headed by *ka*.<sup>19</sup> If *n* fills the head position of this higher FP, then we arrive at the following structure, which we will revise immediately below.

(39) *to be revised below*

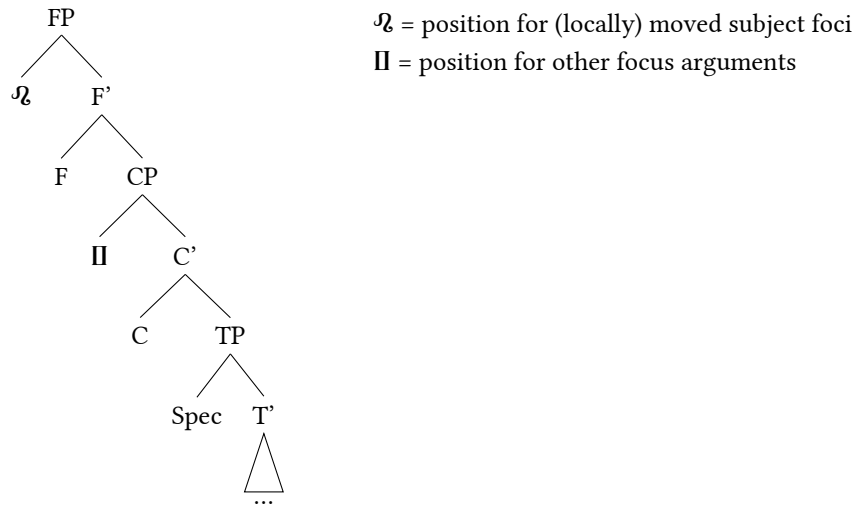

In this structure, the specifier of the higher FP is sufficiently far enough away from Spec,TP such that movement is now possible without violating Spec-to-Spec antilocality. There is a projection between Spec,TP and Spec,FP, namely CP, which is crossed with movement from Spec,TP, and antilocality is not violated. It should be further noted that fairly standard assumptions of economy, such as ‘shortest move’ will restrict this position to matrix subjects. Since all other foci can move to Spec,CP, then they will do so. Local subjects, which are independently not allowed to do so because of antilocality, are only able to move to Spec,FP, and so that is where they move to. We propose that this is roughly the structure that arises for locally moved subjects. FP is generated only when necessary, and is forced to in the case of local subject foci, due to (i) the necessity of the subject to move to the left periphery to license its [*uFocus*] feature; (ii) a prolepsis derivation being unavailable due to the HSR; and (iii) antilocality preventing movement to Spec,CP. In the next subsection, we proceed to refine the structure further, to account for a couple of outstanding issues.

<sup>19</sup>This innovation is partly forced by the functional requirement, identified by Fiedler et al. (2010), that focussed subjects must be marked. This functional requirement will rule out a language that leaves (matrix) subjects obligatorily *in-situ*. Note that this proposal is broadly similar to what Bennet, Akinlabi, and Connell (2012) propose for Defaka, which shows a similar divide amongst focus markers. We discuss their approach in section 6.1 and point out the differences, and why we do not fully assume their analysis there.



## 5.2 The difference between *n* and *ka*

Whilst (39) suffices to allow for movement of local subjects to the left-periphery, it is not quite sufficient for our purposes. Whilst the additional structure gives us the result we need, in order for the account to be insightful, we need to consider the composition of the head labelled F, as two questions arise.

Firstly, positing a generic functional head F is not sufficient, and runs the risk of being a *deus ex machina* without further motivation. The subject moves to the left periphery in order to license its [*uFoc*] feature, and so in order for this to be successful, then F must carry [*iFoc*]. We could propose that Dagbani simply generates an extra phrase that carries focus above the CP that it already has. There would in essence be two focus phrases in the clause. However, despite this simplicity, Rizzi, 1997 has argued that there is maximally one focus head per clause, which is in obvious conflict with a proposal where Dagbani generates another focus phrase on top of CP.<sup>20</sup>

We then propose that the CP is copied to an immediately dominating projection. That is, when the structure is being built, at the point that CP is inserted it is obvious to the derivation that it can no longer converge:  $C_{[iFoc]}$  is too close to the element that bears [*ufoc*]. In order to save this,  $C_{[iFoc]}$  is internally merged once more, which results in the following structure. Crucially, as will become clear in the discussion immediately below, this is not a case of head movement, and so the features on the lower copy are retained in addition to the higher ones. The subject can then move to the specifier of the higher CP, crossing the lower one and not violating antilocality.<sup>21</sup>

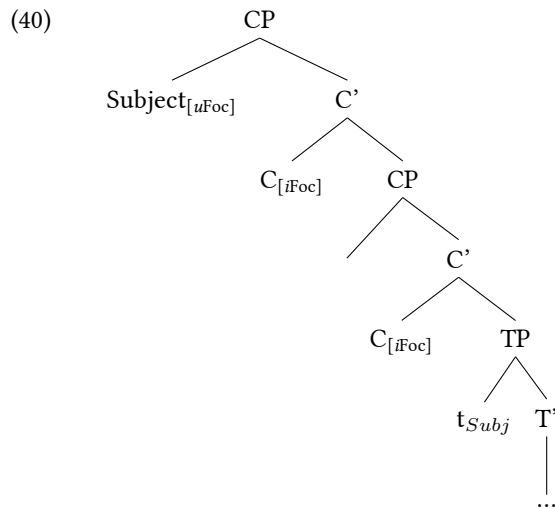

This structure has the result that we can analyse why there are the two focus

<sup>20</sup>Our thanks to an anonymous reviewer, Carlo Cecchetto and Johannes Mursell for all (independently of each other) pointing this out to us.

<sup>21</sup>An anonymous reviewer points out that for this analysis to work, it must be the case that there can be no other projection between TP and CP, otherwise antilocality would present no problem for local subject movement. There is no reason to think that there is another projection here, given that we are not aware of anything that can intervene between T and the focus marker.

markers *n* and *ka*. We propose that *n* represents the spell-out of both Cs, either fused together as is often assumed in Distributed Morphology (Halle and Marantz, 1993), or we have a case of a span spelling out two heads (Svenonius 2012; Merchant 2015, also Abels and Muriungi 2008), as in (41).<sup>22</sup> The rules in (42), are then part of the Dagbani lexicon.

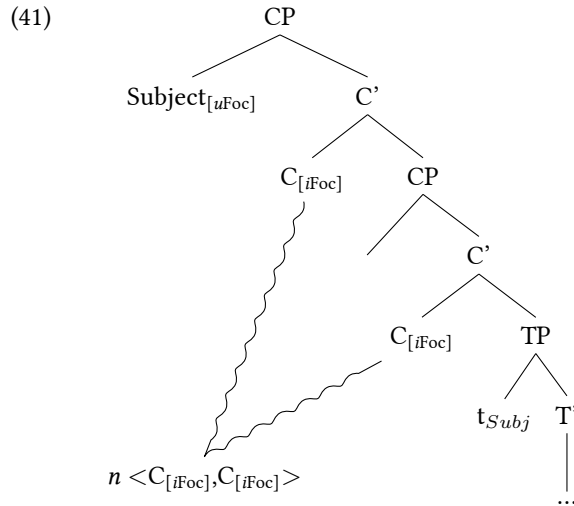

- (42)
- a.  $n \Leftrightarrow \langle C_{[iFoc]}, C_{[iFoc]} \rangle$
  - b.  $ka \Leftrightarrow \langle C_{[iFoc]} \rangle$

Gereon Müller (p.c.) questions how, given that C are featurally identical, the two rules in (42) could be distinguished for the purposes of Vocabulary Insertion (VI). We assume that VI is sensitive to the complexity of certain features, and as such, it can tell the difference between one instance of a feature and two instances of the same feature. There is some evidence that VI is sensitive to such things, particularly within the realm of case. Smith et al. (2015) and Smith et al. (to appear) argue that case features are internally complex and recursive, and that VI can distinguish between [K], which is the unmarked case of a language, say, nominative, and [KK], which would be the dependent case, say, accusative.<sup>23</sup>

In light of this structure, one naturally wonders whether multiple foci are possible in Dagbani, and whether they give evidence for the two positions. However, multiple *ex-situ* foci are not possible in the same clause in Dagbani, and do not let us test the position of a focussed subject relative to a focussed object. Yet, the ban on multiple focus is interesting in the context of our proposed structure, and is worth some further

<sup>22</sup>We represent the portmanteau as Spanning rules merely for convenience, being easier to represent visually, and do not wish to imply that this is preferable to a fusion based analysis. We see no issue with fusion creating a complex head of C and C and the following rules applying. Both approaches seem reasonable, and we have nothing to favour either over the other.

<sup>23</sup>Another option is that there is a difference between the two focus projections that goes beyond structural position, presumably reflective of a difference in semantics (cf. Abels and Muriungi 2008), with the result that there is a tangible difference between the heads which could be identified by some feature. However, it is difficult to pin down what this semantic difference would be.

discussion. In general, if two elements are in focus, one of the elements will move to the left-periphery and the other will stay *in-situ*. Furthermore, in environments where we would expect multiple *wh*-questions, only one of the elements is a *wh*-word, and the other is an indefinite.

- (43) a. \*yà kà ɲùní cháɲ?  
 Where FOC who go.PERF  
 ‘Where has who gone?’  
 b. yà kà só cháɲ?  
 Where FOC someone go.PERF.CJ  
 ‘Where has someone gone?’

We can see both of these as being the result of a general prohibition on multiple foci in Dagbani. Multiple foci are possible, as long as they appear in different clauses as in (44). Therefore, the ban on multiple foci seems to hold only per clause.

- (44) ɲùní ń yèlí nì ɲùní ń kàná  
 who FOC say.PFV that who FOC came.PFV  
 ‘Who said that who came.’

The obvious explanation for the ban on multiple *ex-situ* foci in a single clause is that there can be maximally one specifier of the CP. However, given that we have a shell-CP, with an intermediate position where there can be a specifier, one might expect then that an *ex-situ* object could occupy the lower specifier position. This does not happen, and deserves a little comment here. It is important to note though that we are not proposing that the higher CP is a second focus projection *per sé*. As a reviewer points out, Rizzi (1997) has suggested that there is maximally one focus projection per clause, though there is disagreement over this (Kiss, 1998). Here, we are not proposing that there are multiple focus heads that bring in their own focus semantics. Rather, the expanded CP should be seen as a single instance of focus that is divided across multiple heads in the structure: that is, the higher  $C_{[iFoc]}$  is an extension of an existing one. Thus, descriptively, we can say that the ban on multiple foci in the same clause comes from it being the case that  $[iFoc]$  can only be associated with one argument at a time.

In fact, there is some evidence that it is indeed the case that the two instances of  $C_{[iFoc]}$  work as a unit, and cannot each independently license a focus. For some speakers (2 out of 4 speakers consulted, including the first author of this paper), it is possible to have the following sentence, where both the embedded subject and embedded object are in focus, with the object moving to the matrix clause and the subject locally moving to the embedded left periphery:<sup>24</sup>

<sup>24</sup>The opposite, where the embedded object moves to the embedded left-periphery, and the embedded subject appears in the matrix left-periphery is also fine:

- (i) Napari kà Abu yèlí nì búá kà òì dá.  
 Napari FOC Abu say.PFV that goat FOC 3SG buy.PERF  
 ‘Abu said that NAPARI bought A GOAT.’

On the face of it, this is surprising. It looks as though there should be enough structure such that the

- (45) %búá kà Napari yèlí nì Abu ñ dá  
 goat FOC Napari say.PFV that Abu FOC buy.PFV  
 ‘Napari said that ABU bought a GOAT.’

Suppose that the two instances of [*i*Foc] in the embedded CP could independently license focus on different arguments, then under the assumptions here we would expect that the focussed object would move to the specifier of the lower CP, and no further, given that the trigger of movement – the need to value its unvalued [*u*Foc] feature – would be satisfied at that point. However, the embedded object does move higher, to the matrix left periphery. We propose that this happens because the two instances of [*i*Foc] in the embedded left periphery are the same feature (that is, the feature is shared across multiple heads in the tree, see Pesetsky and Torrego, 2007; Abels, 2012) and as such, whatever one of the instances is related to, the other is as well. As a collective, they then value the [*u*Foc] of the subject, but they cannot independently license different [*u*Foc] features. Since (the two instances of) [*i*Foc] can only be associated with one argument at a time, then the specifier position of the lower CP layer will not be a place where the embedded object can move to and value and license its [*u*Foc]. Thus, in (45), the embedded subject moves to the specifier of the embedded CP, where its [*u*Foc] is valued and licensed by the [*i*Foc] that is shared across the two CP heads. This [*i*Foc] feature cannot then license any other foci. This means that the embedded object must move into the matrix left periphery, in order to find a  $C_{[iFoc]}$  that is unassociated with any other focussed argument. We assume that the embedded object moves through the specifier of the projection hosting *n*<sub>i</sub>, which we take to be the CP head that is the equivalent to the cartographic ForceP, labelled as  $C_{ForceP}$ .<sup>25</sup> The derivation is given below, with irrelevant projections removed:

---

embedded subject can move to Spec,ForceP in order to get into the higher clause, leaving a non-expanded CP in the lower clause. The presence of the resumptive is then surprising. However, we assume that such a derivation is ruled out through minimality considerations (Rizzi, 1990; Rizzi, 2000): if two elements are competing for the same position, the element that moves the shortest wins. Since the subject is only moving from Spec,TP, and the object comes from VP, then the subject will always be the closer argument and expansion of the CP will have to happen whenever a local subject bears [*u*Foc]. Recall from above, though, that the resumptive pronoun does not bear [*u*Foc], and so does not compete for movement to Spec,CP with the focussed object in this example. Therefore, in (i), there is no competition and the object is free to move to Spec,CP.

<sup>25</sup>The label is irrelevant, however, we avoid using ForceP as we have avoided the traditional cartographic labels throughout the rest of the paper.

(46)

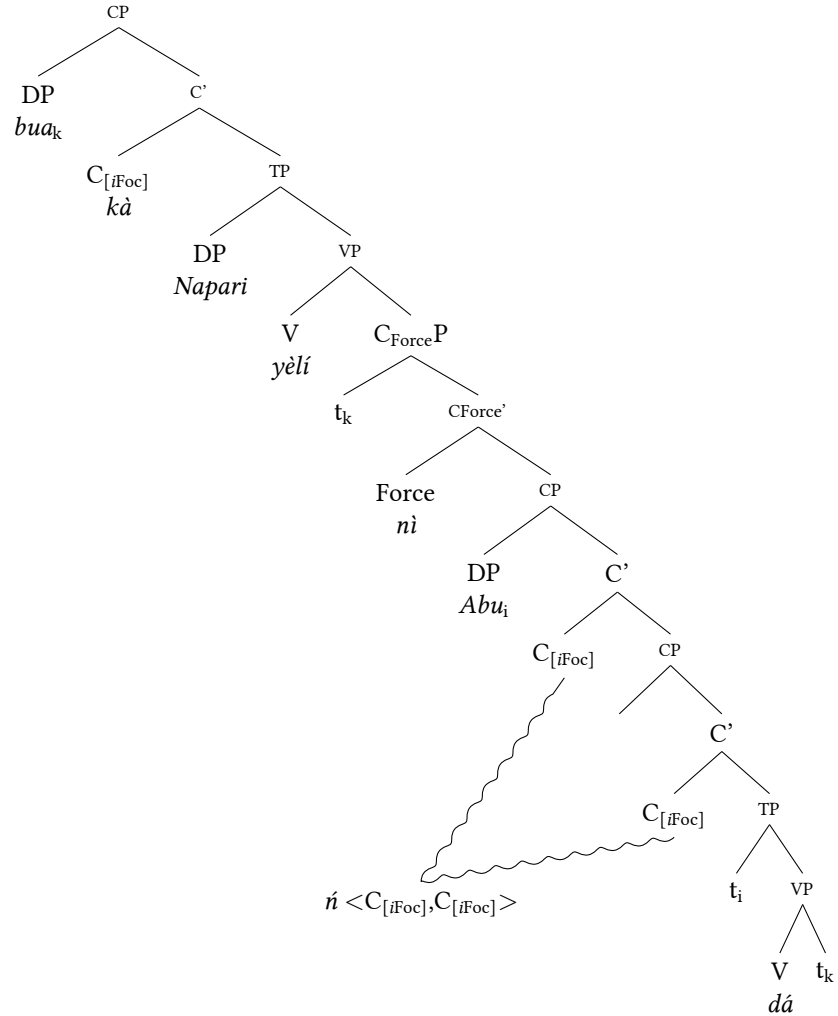

As a final point before leaving this discussion, a reviewer questions why the expansion of CP does not apply in embedded clauses, allowing embedded subjects to move to the matrix clause without having to make use of the resumptive pronoun.<sup>26</sup> That is, what is there to stop the following:

<sup>26</sup>Recall that *n* is possible in embedded clauses, signalling that the expanded FocP is not a root clause phenomenon, see (24) above. However, when a focus appears with *n* in the embedded clause, it cannot move further into the matrix clause.

(47)

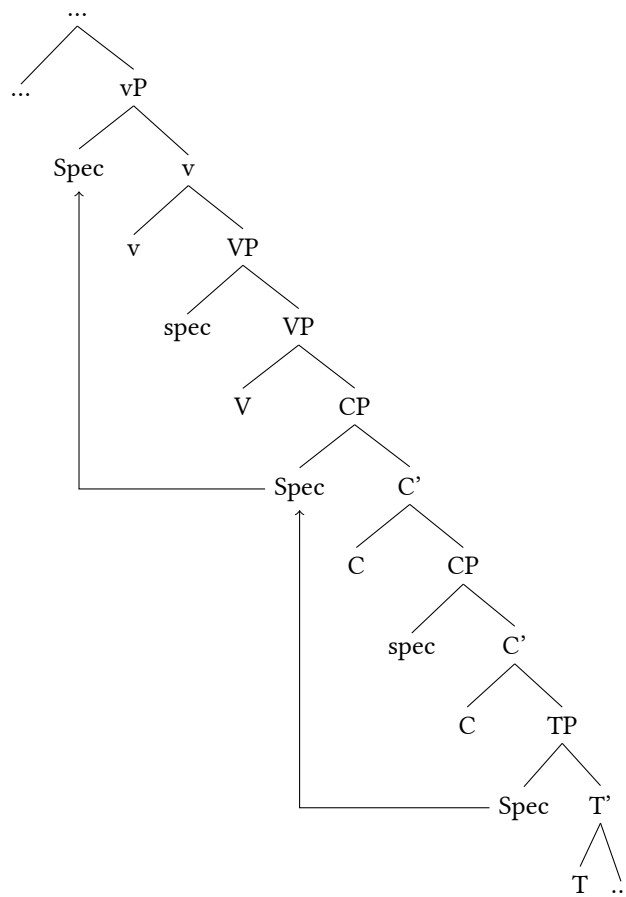

If such a derivation would exist, then we would expect an embedded subject subject to move into the matrix left periphery, but not leave a resumptive pronoun in the lower clause. Given that we do not find such sentences, then we can be confident that the derivation does not exist. However, the question is why. The best speculation that we can give to this is that copying the C head is a marked option (potentially instructive as to why Dagbani type languages with two focus markers appear to be quite uncommon). The copying of CP happens only as a last resort option, when nothing else will let the derivation converge. The option of using prolepsis for subjects in embedded clauses could mean that there is nothing to force the iteration of the embedded CP. That is, it is in some sense more economical to use prolepsis that making the complex CP that is needed to allow an embedded subject to extract. One could handle this in terms of OT-style ranked constraints, broadly along the lines of Salzmänn (2013). Unfortunately, due to space restrictions we cannot explore this any further here. However, we refer the reader to Authors (in prep) where we discuss constraint violations of these types in further detail across a larger sample of West African languages.

## 6 Comparison with an Alternative Analysis: C-T Bundling

In this section we contrast our analysis of Dagbani with another approach that has recently been proposed where languages have difficulty moving subjects. The approach bundles C and T together to form a complex head, which we follow these authors in terming CT. The idea in brief is as follows: since subjects seem to have difficulty moving from Spec,TP to Spec,CP (whether this is due to antilocality or some other constraint is orthogonal to the current point), then a language can bundle the heads C and T onto the same node, and this head can fulfill the requirements of both the C and the T with the same argument in the same position, namely in its specifier. Such a head will be responsible for the EPP, as well as information structural related movements in the language. We first illustrate this in more detail, before discussing why we do not believe that it is applicable to Dagbani.

### 6.1 Bundling in Defaka

We illustrate the idea of bundling heads together with data from Defaka (Bennet, Akinlabi, and Connell, 2012). There is an important clarification to be made below regarding the position of subjects, but given that the phenomena that Bennet, Akinlabi, and Connell attempt to account for with bundling is basically the same, it allows for ease of exposition. Defaka is an Ijoid language spoken in Nigeria. Like Dagbani, it has two (relevant) focus markers, whose use is determined according to the position where the focalised element has come from. Local subject movement results in *kò*, whereas non-local subjects use *ndò*, as exemplified below.<sup>27</sup>

- (48) a. *i Bòmá ésé-kà-rè*  
I Boma see-FUT-NEG  
'I will not see Boma.' (neutral) [Bennet, Akinlabi, and Connell 2012, p. 1]
- b. *i kò Bòmá ésé-kà-rè*  
I FOC Boma see-FUT-NEG  
'I will not see Boma.' (subject focus) [Bennet, Akinlabi, and Connell 2012, p. 1]
- c. *Bòmá ndò i ésé-kà-rè-kè*  
Boma FOC I see-FUT-NEG-KE  
'I will not see Boma.' (object focus) [Bennet, Akinlabi, and Connell 2012, p. 1]

Defaka has in common with Dagbani that embedded subjects can use either focus marker, depending on where the final position of the focussed element is; if the focus element lies to the left of the matrix clause, then *ndò* is used, however if the embedded subject moves only as far as the left periphery of the embedded clause, then *kò* is used, hence the characterisation as local subject movement vs. other.

<sup>27</sup>Defaka differs from Dagbani in that non-local subject movement results in the insertion of the clitic *kè* on the verb. Bennet, Akinlabi, and Connell (2012) take this to be a marker of A'-movement from within the vP phase. Such a marker of A'-movement is not displayed in Dagbani to the best of our knowledge, and so we ignore this aspect of Defaka.





	Past	Present	Habitual	Future			
sà	‘yesterday’	yólí	‘just’	yì	‘normally’	ní	future
dàà	‘2+ days ago’	ná	‘still/yet’			kù	‘negative future’
dì	‘earlier today’						

Table 3: Tense marking in Dagbani

projected in Dagbani. Bennet, Akinlabi, and Connell (2012) assume a SubjP because they assume movement of vP to Spec,TP, leaving no place for the subject but a higher position. However, this clearly does not happen in Dagbani, and there is then no reason to suspect that the subject does not lie in Spec,TP. In the absence of compelling evidence for SubjP in Dagbani, we will assume that T is responsible for the licensing of subjects.

With this in mind, then we consider the bundling approach that is exemplified by Martinović (2015) and Erlewine (in press), where it is C and T that are bundled together, to be the relevant approach to contrast ours with. In this approach, following Chomsky (2008), the probes that are on T originally begin life on C, but are transferred to T during the course of the derivation. In effect, the functional information of T is bundled with that of C at an early stage. This allows in principle the splitting apart of C and T probes to not take place, and C and T can remain bundled in a complex head, called CT, which carries out the duties of both C and T. In the relevant sense here, CT would be able to license both the EPP feature, traditionally on T, and the focus feature, traditionally on C, as a single head.

Though we have no objection to this analysis for the phenomena that Martinovic and Erlewine discuss, the clearest piece of evidence against this analysis is that if *n* were CT, then we do not expect T and *n* to cooccur on separate morphemes as on the CT approach they will be realised by the same head. For some sentences, this is correct as T is not always realised. Dagbani has both aspectual and tense morphology. Aspect is synthetically realised on the verb, appearing between the verbal root and the conjoint/disjunct marker. We take this to mean that the verb moves as high as Asp. Tense marking, by contrast is realised by the use of preverbal particles. These particles express different points in time, including various distinctions in the past, present, habitual and the future. A list of tense markers in Dagbani is given in Table 3.

Now, if *n* were the realisation of a CT bundle, then we would expect that *n* and tense marking could not cooccur. However, this is not the case, as can be seen in (54). In that respect it behaves exactly as *ka*, suggesting they are oth equally focus markers.

- (52) a. Abu ń sà dá lòòri  
 ABU FOC yesterday buy.PERF car  
 ‘Abu bought a car yesterday.’  
 b. Napari míni Mbangba kà tí sà pùhí.  
 Napari and Mbangba FOC 1PL PST greet  
 ‘We greeted NAPARI and Mbangba yesterday.’

T and *n* are realised by different heads, and as such, *n* is not a bundle of C/Foc and T. It should also be noted that the same facts are reported for Gurene and Kusaal data

reported in section 3.1 (see in particular (9) and (10)).

Now, one may question whether these markers are really realisations of T heads, rather than adverbials. However, Hartmann and Sam Alhassan Issah (2018) argue conclusively that these are not adverbials, but rather show the properties one would expect of heads. Firstly, tense marking can cooccur with adverbials. There is, however, an asymmetry between the two in that the use of an adverbial necessarily leads to the appropriate tense marker, yet this relationship is unidirectional, in that the use of a tense marker does not necessitate the appearance of an adverbial. Tense marking is thus obligatory where a temporal interpretation is intended, whereas adverbials are optional.

- (53) a. *Ábú sà bú bíhí máa.*  
 Abu PAST beat.PERF children DEF  
 ‘Abu beat the children yesterday.’  
 b. \**Ábú bú bíhí máa sòhílá.*  
 Abu beat.PERF children DEF yesterday

Note further that in (54), the tense marker is obligatory, and the intended meaning cannot be expressed without it, using only the focus marker:

- (54) #*Abu ñ dá lòòri*  
 ABU FOC buy car  
*intended:* ‘Abu bought a car yesterday.’

A further difference between tense markers and adverbials is that the tense markers are preverbal, whereas adverbials are post-verbal in Dagbani.

- (55) *Ò dáa tí bíhí máa lìgírí bákói dín gàrí lá.*  
 3SG PST give.PFV children DEF money week DEF pass EVI  
 ‘S/he gave the children money last week.’

Thus, we can conclude from this data that the preverbal tense markers are manifestations of the functional head T, and thus, the fact that they cooccur with *n* shows that *n* is not a CT bundle, but rather they are separate functional heads in the clausal spine.

## 7 Conclusions

Our aim in this paper was to present and analyse the fairly intricate system of *ex-situ* focus in Dagbani, and explore how the facts can be accounted for. As mentioned at the outset, one has to offer an explanation for how Dagbani makes a three-way distinction of *ex-situ* focus properties, caused by inconsistent behaviour of subjects which behave differently according to whether they are focussed locally or non-locally. On the one hand, local subject focus and non-subjects share the fact that they cannot escape syntactic islands, in contrast to non-local subject focus. On the other hand, non-local subject focus and non-subjects share the fact that the element in the left-periphery occurs with the focus marker *ka*, whereas local subject focus results in *n*.

On the other hand, local subjects and non-subjects do not use resumptive pronouns, but non-local subjects do. We have argued that these properties are interlinked, and all arise from subjects needing to move to Spec,TP and Spec,CP, which is well known to pose challenges in many languages. Dagbani is in no way unique in facing challenges with subject extraction, however, the manner in which Dagbani resolves the known challenges results in a somewhat unique system of *ex-situ* focus in the language.

Underlying the differing behaviour of subjects in Dagbani are considerations of antilocality, which prevents a subject from moving to Spec,CP after having visited Spec,TP. Whilst some languages resolve this issue by having the subject avoid Spec,TP altogether (or by some other way), Dagbani makes use of prolepsis derivation in the case of non-local subject movement. This prolepsis derivation is however otherwise unavailable to subjects moving locally due to the Highest Subject Restriction.<sup>29</sup> The unavailability of prolepsis has led to Dagbani (and by hypothesis the other languages that have developed two focus markers in the same way, see section 3.1) developing a strategy for allowing subjects to move locally, and still be able visit Spec,TP and the specifier of CP. We argued that Dagbani forms a complex CP layer, by copying the features on C to a projection immediately above, in effect forming a layered CP.

As ever, a number of interesting issues were raised along the way that we were unable to discuss due to space limitations. One is the formulation of antilocality itself. We have discussed a version following Erlewine (2016) and Douglas (2017) where (A'-)movement from Spec,TP is unable to proceed unless the moved element crosses a phrase other than TP (more accurately Spec, $\phi$ P, see above). As noted in the introduction, there are various formulations of antilocality, and little agreement amongst them over what should count as too short, other than the proposal that there is some conception that movement cannot be too short. As noted at the outset, one can have various reservations about this formulation (see section 1 and footnote 15), amongst them its formulation only in terms of A'-movement. Perhaps importantly, our analysis of Dagbani does not seem immediately compatible with the characterisation of antilocality given in either Grohmann (2003) or Bošković (2005). To the extent that our characterisation of these phenomena in Dagbani has been correct then, we have lent further support for the characterisation of antilocality in Erlewine (2016) and Douglas (2017).

At a descriptive level, our paper offers an improvement on previous descriptions and analyses of Dagbani where the choice between *n* and *ka* is conditioned by either being a subject or a non-subject. Given the variable behaviour of subjects outlined above, then such a characterisation is not tenable, and we have shown that it is better described as the difference between local subject focus, non-local subject focus and non-subject focus.

## Abbreviations

ACC = accusative, C = complementiser, CJ = conjoint, COP = copular, DEF = definite, DJ = disjoint, EMPH = emphatic, EVI = evidential, F = feminine, FOC = focus, IMPERF

---

<sup>29</sup>And, for non-subjects a general preference for movement over prolepsis (handled by a transderivational constraint of the sort offered in Salzmann 2013).

= imperfective, LOC = locative, PART = participle, PERF = perfective, PST = past, PL = plural, PROG = progressive, Q = question particle, SG = singular, WH = question particle

## References

- Abels, Klaus (2003). “Successive Cyclicity, Anti-Locality, and Adposition Stranding”. PhD thesis. Storrs, CT: University of Connecticut.
- (2012). *Phases: An essay on cyclicity in syntax*. Vol. 543. Linguistische Arbeiten. Berlin: Walter de Gruyter.
- Abels, Klaus and Peter Muriungi (2008). “The focus marker in Kĩitharaka: Syntax and semantics”. In: *Lingua* 118.5, pp. 687–731.
- Abubakari, Hasiyatu (2016). *Contrastive focus particles in Kusaal*. Poster presented at ACAL 47.
- Adesola, Oluseye (2005). “Pronouns and null operators – A-bar dependencies and relations in Yoruba”. MA thesis. New Brunswick, NJ: Rutgers University.
- (2010). “The non-agreeing subject resumptive pronoun in Yoruba”. In: ed. by Enoch Aboh and James Essegbey. Dordrecht: Springer, pp. 65–89.
- Aoun, Joseph, Lina Choueiri, and Norbert Hornstein (2001). “Resumption, movement and derivational economy”. In: *Linguistic Inquiry* 32.3, pp. 371–403.
- Authors (in prep). *Subject extraction strategies in West African languages*. Manuscript.
- Bennet, Wm G., Akinbiyi Akinlabi, and Bruce Connell (2012). “Two subject asymmetries in Defaka focus constructions”. In: *Proceedings of the 29th West Coast Conference on Formal Linguistics*. Ed. by Jaehoon Choi, E. Alan Hogue, Jeffrey Punske, Deniz Tat, Jessamyn Schertz, and Alex Trueman. Somerville, MA: Cascadilla Proceedings Project, pp. 294–302.
- Bobaljik, Jonathan D. and Dianne Jonas (1996). “Subject Positions and the Roles of TP”. English. In: *Linguistic Inquiry* 27.2, pp. 195–236.
- Bobaljik, Jonathan D. and Hoskuldur Thráinsson (1998). “Two Heads Aren’t Always Better Than One”. English. In: *Syntax* 1.1, pp. 37–71.
- Boeckx, Cedric (2003). *Islands and chains: Resumption as stranding*. Amsterdam: John Benjamins Publishing Company.
- Bošković, Željko (2005). “On the Locality of Left Branch Extraction and the Structure of NP”. English. In: *Studia Linguistica* 59.1, pp. 1–45.
- (2007). “On the Locality and Motivation of Move and Agree: An Even More Minimal Theory”. English. In: *Linguistic Inquiry* 38.4, pp. 589–644.
- (2016). “On the timing of labeling: Deducing Comp-trace effects, the Subject Condition, the Adjunct Condition, and tucking in from labeling”. In: *The Linguistic Review* 33.1, pp. 17–66.
- Carstens, Vicki (2002). “Antisymmetry and word order in serial constructions”. In: *Language* 78, pp. 3–50.
- Chomsky, Noam (1981). *Lectures on Government and Binding*. Dordrecht: Foris.
- (1995). *The Minimalist Program*. Cambridge, MA: MIT Press.
- (2008). “On Phases”. In: *Foundational Issues in Linguistic Theory: Essays in Honor of Jean-Roger Vergnaud*. Ed. by Robert Freidin, Carlos P. Otero, and Maria Luisa Zubizarreta. Vol. 133-165. MIT Press.

- Chomsky, Noam (2013). "Problems of Projection". In: *Lingua* 130, pp. 33–49.
- Dakubu, M. E. Kropp (2003). *Interrogative structures in Farefare*. Manuscript, Insitute of African Studies, University of Ghana.
- Douglas, Jamie (2017). "Unifying the *that*-trace and anti-*that*-trace effects". In: *Glossa* 2.1, pp. 1–28.
- Dumah, Irene Basimaga (2016). *Focus Marking in Sisaali*. Manuscript.
- Engdahl, Elisabet (1985). "Parasitic gaps, resumptive pronouns and subject extractions". In: *Linguistics* 23.1, pp. 3–44.
- Epstein, Samuel and T. Daniel Seely (1999). *SPEC-ifying the GF "subject:" eliminating A-Chains and the EPP within a Derivational Model*. Ms. University of Michigan.
- Erlewine, Michael Yoshitaka (in press). "Extraction and licensing in Toba Batak". In: *Language* 94.3.
- (2016). "Anti-locality and optimality in Kaqchikel Agent Focus". In: *Natural Language and Linguistic Theory* 34.429-479.
- Fiedler, Ines, Katharina Hartmann, Brigitte Reineke, Anne Schwarz, and Malte Zimmermann (2010). "Subject focus in West African languages". In: *Information structure: theoretical, typological and experimental perspectives*. Ed. by Malte Zimmermann and Caroline Féry. Oxford: Oxford University Press, pp. 234–257.
- Grohmann, Kleanthes (2003). *Prolific domains: on the antilocality of movement dependencies*. Amsterdam: John Benjamins.
- (2011). "Anti-Locality: too close relations in grammar". In: *The Oxford handbook of linguistic Minimalism*. Ed. by Cedric Boeckx. Oxford, pp. 260–290.
- Halle, Morris and Alec Marantz (1993). "Distributed Morphology and the Pieces of Inflection". In: *The View from Building 20*. Ed. by Ken Hale and Samuel Jay Keyser. Cambridge, MA: MIT Press, pp. 111–176.
- Hartmann, Katharina and Sam Alhassan Issah (2018). "The conjoint – disjoint alternation in Dagbani". Ms. Goethe Universität Frankfurt.
- Hartmann, Katharina and Malte Zimmermann (2007a). "Focus strategies in Chadic – the case of Tangele". In: *Studia Linguistica* 61.2, pp. 95–129.
- (2007b). "In place – out of place? Focus in Hausa". In: *On information structure, meaning and form: Generalizing across languages*. Ed. by Kerstin Schwabe and Susanne Winkler. Amsterdam and Philadelphia: John Benjamins Publishing Company, pp. 365–403.
- (2009). "Morphological focus marking in Gùrùntùm". In: *Lingua* 119.9, pp. 1340–1365.
- (2012). "Focus marking in Bura: Semantic uniformity matches syntactic heterogeneity". In: *Natural Language and Linguistic Theory* 30.4, pp. 1061–1108.
- Hudu, Fusheini (2010). "Dagbani tongue-root harmony: A formal account with ultrasound investigation". PhD thesis. Vancouver, BC: University of British Columbia.
- Issah, Samuel Alhassan (in prep). "The Structure of Constituent Questions in Dagbani." PhD thesis. Frankfurt am Main: Johann Wolfgang Goethe-Universität.
- (2008). "Information packaging in Dagbani". MA thesis. University of Tromsø.
- (2012). "Phrasal identificational and contrastive focus in Dagbani". In: *Journal of West African Languages* 39.1, pp. 75–96.

- Kalinowski, Cristin (2015). "A Typology of Morphosyntactic encoding of focus in African languages". PhD thesis. Buffalo, NY: State University of New York at Buffalo.
- Kandybowicz, Jason (2007). *The grammar of repetition: Nupe grammar at the syntax-phonology interface*. Amsterdam: John Benjamins Publishing Company.
- Kiss, Katalin É (1998). "Multiple topic, one focus?" In: *Acta Linguistica Hungarica* 45.1-2, pp. 3–29.
- Landau, Idan (2006). "Chain resolution in Hebrew V(P) fronting". In: *Syntax* 9, pp. 32–66.
- Leffel, Timothy (2011). *Focus constructions in Masalit*. Manuscript, NYU.
- Martinović, Martina (2015). "Feature geometry and head-splitting: Evidence from the morphosyntax of the Wolof clausal periphery". PhD thesis. Chicago, IL: University of Chicago.
- McCloskey, James (1979). *Transformation Syntax and Model Theoretic Semantics: A Case Study in Modern Irish*. Dordrecht: Reidel.
- (1990). "Resumptive Pronouns, A'-Binding, and Levels of Representation". In: *The Syntax of the Modern Celtic Languages*. Ed. by Randall Hendrick. Vol. 23. Syntax and Semantics. Academic Press, pp. 199–248.
- (1996). "Subjects and subject positions in Irish". In: *The Syntax of the Celtic Languages*. Ed. by Robert D. Borsley and Ian Roberts. Cambridge University Press, pp. 241–283.
- Merchant, Jason (2015). "How much context is enough? Two cases of span-conditioned stem allomorphy". In: *Linguistic Inquiry* 46.2, pp. 273–303.
- Olawsky, Knut J. (1999). *Aspects of Dagbani Grammar*. München: Lincom Europa.
- Ouhalla, Jamal (1993). "Subject-extraction, negation and the anti-agreement effect". In: *Natural Language and Linguistic Theory* 11, pp. 477–518.
- Pesetsky, David and Esther Torrego (2007). "The syntax of valuation and the interpretation of features". In: *Phrasal and clausal architecture*. Ed. by V. Samiian S. Karimi and W. Wilkins. John Benjamins, pp. 262–294.
- Pollock, Jean-Yves (1989). "Verb movement, Universal Grammar, and the structure of IP". In: *Linguistic Inquiry* 20.3, pp. 365–424.
- Richards, Norvin (1997). "What moves where when in which language?" PhD thesis. Cambridge, MA: MIT.
- Rizzi, Luigi (1990). *Relativized Minimality*. Cambridge, MA: MIT Press.
- (1997). "The fine structure of the left periphery". In: *Elements of grammar, handbook in generative syntax*. Ed. by Liliane Haegeman. Dordrecht: Kluwer, pp. 281–337.
- (2000). "Relativized Minimality Effects". In: *The Handbook of Contemporary Syntactic Theory*. Ed. by Mark Baltin and Chris Collins. Blackwell, pp. 89–110.
- Rizzi, Luigi and Ur Shlonsky (2007). "Strategies of subject extraction". In: *Interfaces + recursion = language? Chomsky's minimalism and the view from syntax-semantics*. Ed. by Uli Sauerland and Hans-Martin Gärtner. Vol. 89. Studies in Generative Grammar. Berlin: de Gruyter, pp. 115–160.
- Ross, John Robert (1967). "Constraints on Variables in Syntax". PhD thesis. Cambridge, MA: MIT.
- Saah, Kofi Korankye (1994). "Studies in Akan syntax, acquisition and processing". PhD thesis. University of Ottawa.

- Salzmann, Martin (2011). “Silent resumptives in Zurich German possessor relativization”. In: *Null Pronouns*. Ed. by Peter Gallman and Melanie Wratil. Mouton de Gruyter, pp. 141–221.
- (2013). “On three types of variation in resumption: evidence in favor of violable and ranked constraints”. In: *Linguistic derivations and filtering*. Ed. by Hans Broekhuis and Ralf Vogel. Equinox, pp. 76–108.
  - (2017). “Prolepsis”. In: *The Wiley-Blackwell Companion to Syntax*. Ed. by Martin Everaert and Henk van Riemsdijk. Vol. 5. London: Wiley-Blackwell, pp. 3203–3245.
  - (2018). *Indirect A'-dependencies. Studies on resumption and relativization in (Swiss) German and beyond*. Berlin: Walter de Gruyter.
- Salzmann, Martin, Jana Häussler, Josef Bayer, and Markus Bader (2013). “That-trace effects without traces : an experimental investigation”. In: *The proceedings of NELS 42*, pp. 149–162.
- Shlonsky, Ur (1992). “Resumptive pronouns as a last resort”. In: *Linguistic Inquiry* 23.3, pp. 443–468.
- Sichel, Ivy (2014). “Resumptive pronouns and competition”. In: *Linguistic Inquiry* 45, pp. 655–693.
- Smith, Peter W., Beata Moskal, Ting Xu, Jungmin Kang, and Jonathan D. Bobaljik (to appear). “Case and number suppletion in pronouns”. In: *Natural Language and Linguistic Theory*.
- (2015). “Pronominal Suppletion: Case and Number”. In: *The Proceedings of NELS 45*. Ed. by Thuy Bui and Deniz Özyıldız. Vol. 3. Amherst, MA: GLSA, pp. 69–78.
- Svenonius, Peter (2012). “Spanning”. Manuscript.
- Van Urk, Coppe (2017). *Phase impenetrability and resumption in Dinka*. Talk at GLOW 40, Leiden.
- (2018). “Pronoun copying in Dinka Bor and the copy theory of movement”. In: *Natural Language and Linguistic Theory* 36, pp. 937–990.